

ALERT SERVICE BULLETIN

REPLACEMENT OF FUEL PUMP

FOR ROTAX[®] ENGINE TYPE 912 (SERIES) SB-912-053

MANDATORY

Repeating symbols:

Please, pay attention to the following symbols throughout this document emphasizing particular information.

- ▲ **WARNING:** Identifies an instruction, which if not followed, may cause serious injury or even death.
- **CAUTION:** Denotes an instruction which if not followed, may severely damage the engine or could lead to suspension of warranty.
- ◆ **NOTE:** Information useful for better handling.

1) Planning information

1.1) Engines affected

All versions of the engine type:

- 912 A from S/N 4,410.684 to S/N 4,410.727
- 912 F from S/N 4,412.913 to S/N 4,412.925
- 912 S from S/N 4,923.282 to S/N 4,923.461

all parts

- Fuel pump part no. 892230, 892232, 892540 (standard version) and part no. 892235, 892236, 892545 (version including flexible fuel line), which was supplied as a spare part.
- Also affected are all engines and gearboxes in which the above mentioned fuel pumps were installed at engine repair/general overhaul as a spare part during the supply period starting January, 2006.
- ◆ **NOTE:** All engines and gearboxes that were already retrofitted with a new fuel pump part no. 892542 or 892546 are not affected.

1.2) Concurrent ASB/SB/SI and SL

none

1.3) Reason

Due to high fuel pressure, caused by exceeding pressure in front of the mechanical fuel pump (e.g. due to an electrical fuel pump), in limited cases a deviation in the fuel supply could occur. This can result in exceeding of the fuel pressure and might cause engine malfunction and/or massive fuel leakage.

1.4) Subject

Replacement of fuel pumps with part no. 892230, 892232, 892540 through part no. 892542 and Replacement of fuel pumps with part no. 892235, 892236, 892545 through part no. 892546 for ROTAX[®] engine type 912 (Series).

1.5) Compliance

- before the first installation
- At the next maintenance event, but within the next 25 hours of operation.
- At the latest July 1st 2007.
- ▲ **WARNING:** The replacement has to be performed regardless the SB-912-050, "Checking or replacement of fuel pump part no. 892230/892235"!
Non-compliance with these instructions could result in engine damages, personal injuries or death.

1.6) Approval

The technical content is approved under the authority of DOA Nr. EASA.21J.048.

1.7) Manpower

Estimated man-hours:

Engine installed in the aircraft - - -manpower time will depend on installation and thus, no estimate is available from the engine manufacturer.

1.8) Mass data

Change of weight - - - none.

Moment of inertia - - - unaffected.

1.9) Electrical load data

No change

1.10) Software accomplishment summary

No change

1.11) References

In addition to this technical information refer to current issue of

- Operator's Manual (OM)

- Illustrated Parts Catalog (IPC)

- Maintenance Manual (MM)

◆ NOTE: The status of Manuals can be determined by checking the table of amendments of the Manual. The 1st column of this table is the revision status. Compare this number to that listed on the ROTAX WebSite: www.rotax-aircraft-engines.com. Updates and current revisions can be downloaded for free.

1.12) Other publications affected

The following documentations must be replaced as a consequence of this Alert Service Bulletin and will become invalid therefore.

- SB-912-050 "Checking or replacement of fuel pump part no. 892230/892235", current issue

1.13) Interchangeability of parts

All used parts which cannot be used must be returned F.O.B. to a ROTAX[®] Authorized Distributors or Service Centers.

2) Material Information

2.1) Material - cost and availability

Price and availability will be supplied on request by ROTAX[®] Authorized Distributors or their Service Centers.

2.2) Company support information

None

2.3) Material requirement per engine

parts requirement:

Fig.no.	New part no.	Qty/engine	Description	Old part no.	Application
	892542*	1	fuel pump assy.	892230/232/540	fuel system
	892546*	1	fuel pump assy. with fuel line	892235/236/545	fuel system

* dependent of engine type (see IPC), gasket is included in the fuel pump assy.

2.4) Material requirement per spare part

None

2.5) Rework of parts

None

2.6) Special tooling/lubricant-/adhesives-/sealing compound - Price and availability

None

3) Accomplishment/Instructions

Accomplishment

All the measures must be taken and confirmed by the following persons or facilities:

- ROTAX[®] -Airworthiness representative
- ROTAX[®] -Distributors or their Service Centers
- Persons approved by the respective Aviation Authority

▲ **WARNING:** Proceed with this work only in a non-smoking area and not close to sparks or open flames. Switch off ignition and secure engine against unintentional operation. Secure aircraft against unauthorized operation. Disconnect negative terminal of aircraft battery.

▲ **WARNING:** Risk of scalds and burns! Allow engine to cool sufficiently and use appropriate safety gear while performing work.

▲ **WARNING:** Should removal of a locking device (namely lock tabs, self-locking fasteners) be required when undergoing disassembly/assembly, always replace with a new one.

◆ **NOTE:** All work has to be performed in accordance with the relevant Maintenance Manual.

3.1) Instructions

3.1.1) Replacement of the fuel pump

(see Fig.1)

1. Remove fuel pump (1).
2. Gasket (2) replaced by new part.

■ **CAUTION:** Install new gasket supplied with new fuel pump. The thickness is different.

3. Install fuel pump. Tightening torque 15 Nm (133 in.lb).
4. Install fuel line.

3.1.2) Checking and replacement of the electric (auxiliary) fuel pump

Check output pressure and flow rate of electric (auxiliary) fuel pump as per current ROTAX Installation Manual. Repair or replace any pump that does not meet requirements.

- Restore aircraft to original operating configuration.
- Connect negative terminal of aircraft battery.

3.2) Test run

Conduct test run including ignition check and leakage test.

3.3) Summary

These instructions (section 3) have to be conducted in compliance with section 1.5.

Confirm the implementation of the specified Alert Service Bulletin in the Engine Log book.

Approval of translation to best knowledge and judgment - in any case the original text in the German language and the metric units (SI-system) are authoritative.

4) Appendix

The following drawings should provide additional information:

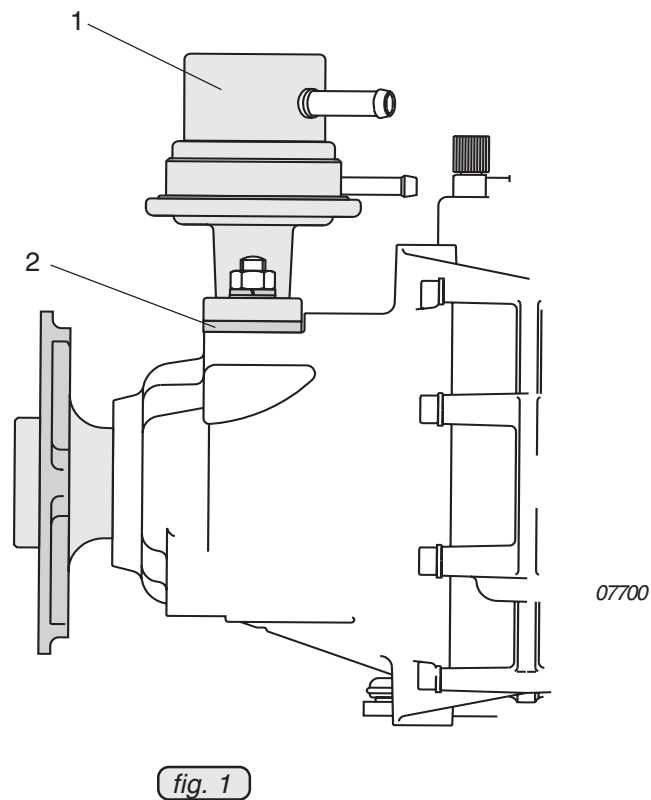
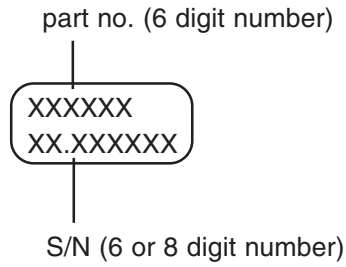

- ◆ NOTE: The illustrations in this document show the typical construction. They may not represent full detail or the exact shape of the parts which have the same or similar function.
Exploded views are **not technical** drawings and are for reference only. For specific detail, refer to the current documents of the respective engine type.